

H series online UPS LCD 1-3KS/L



User's manual

Thank you for purchasing our UPS, it is safe and reliable, needs few maintenance.

☆ This manual includes instructions of safety installation and operation, they help your UPS to have the longest service life. This manual also accounts the UPS work principle and relative functions.

☆ Please obey the instructions and notes stated in this manual. Keep this manual in a safe place, consult it before operation.

Safety rules

- Even if not connected to main power, high voltage may still presents at UPS outlets.
- If the external battery cord or power cord needs to be replaced, please contact our service station or franchiser for replacing to avoid fire disaster caused by insufficient capacity of such items. Don't dispose of battery or batteries group in a fire, otherwise, it can cause explosion and harm to people. Don't open the battery or do the battery damage, for the liquid spilled from battery is strongly poisonous and do harmful to body.
- Please avoid short-circuit between battery anode and cathode; otherwise, this will cause electric shock or fire.
- Don't dismantle the UPS cover, there is danger of electric shock.
- Don't touch batteries. Batteries are not isolated with the input circuit, there is high voltage between the battery terminals and ground.
- Don't connect with the electric equipment such as blower, heater, drilling machine etc. They may damage the UPS.

Notice:

There presents high voltage in UPS. If there is any abnormal problem present, please consult the service center and do not attempt to repair the equipment under any circumstances. The address of service center has been detailed on the warranty card.

Note: POCASA reserves the right to make changes to product described in this manual at any time and without notice for reasons of improvement.

Contents

1. Brief introduction-----	4
1.1. Technology introduction-----	4
1.2. System and model description-----	5
1.3. Description of commonly used symbols-----	5
1.4. Appearance-----	6
1.5. Product specification and performance-----	8
2. Installation-----	8
2.1. Unpacking and inspection-----	9
2.2. Safety notes-----	9
2.3. The description of front panel and display lamp-----	10
2.4. UPS input connection-----	11
2.5. UPS output connection-----	12
2.6. External battery connection-----	13
3. Operation and operating mode-----	14
3.1. Operation-----	14
3.2. Operating mode-----	15
4. Notes for battery disposal and battery replacement-----	20
5. Troubleshooting-----	21
Appendix: EMC grade standards-----	23

1. Brief introduction

1.1. Technology introduction

- This UPS is a sophisticated piece of equipment with 16 bit Microprocessor and advanced software programming technology, high frequency SPWM is created to control the inverter of UPS. This simplifies the control circuit, enhances the stability of UPS, also enables the UPS to have enhanced real-time performance that makes UPS respond the variety of external environment rapidly and insure that the control circuit is compact and reliable.
- Digital control technology to avoid the temperature excursion of hardware specification
- Self-diagnoses before startup help UPS to find potential failure to avoid any losses
- Double conversion on-line topology, which makes the UPS a pure sine wave machine with constant frequency, constant voltage, low noise and no interruption with mains power fluctuation, it protect the user's equipments ideally all the time.
- No transfer time when main power fail or main power restore, meets the requirements of precision instruments.
- Standard bypass function
When UPS meets a fault, it can transfer to bypass seamlessly and provide alarm.
- Advanced voltage compensation technology, makes the wide input voltage range, reducing the battery usage, enhancing the adaptive ability against the bad mains power variation.
- Advanced wide frequency input technology
Wide input frequency range of UPS gives UPS a good compatibility with generator under field circumstances.
- The advanced PFC technology on the input of UPS, improves the input power factor close to unity, raises the power efficiency, removes the harmonic noise from UPS to utility, lowers UPS operational costs, it's really an environmental friendly protection power supply.
- Smart management function
Under mains power blackout, UPS would transfer to battery mode to supply power to loads, when battery voltage is low, UPS would protect itself and shuts down automatically. When main power restores, UPS would be turned on automatically to supply power to loads.
- Cold start function
When there is no input, UPS can be turned on with battery pack, to meet the user's emergency needs. The cold start function is quite strong. UPS can be cold started on full load situation.
- Fault operation prevention function
Every button has delay function, only when you press and hold the button for a certain time, required

operation can be activated.

- Smart management function

Under mains power blackout, UPS would transfer to battery mode to supply power to loads, when battery voltage is low, UPS would protect itself and shuts down automatically. When main power restores, UPS would be turned on automatically.

- Via internal or external SNMP card, UPS can go on internet, you can monitor and manage the UPS status through all kinds of network management system.

1.2. System and model description

H online series is an uninterruptible power supply incorporating double-conversion technology. It provides perfect protection specifically for computer equipment communication systems to computerized instruments.

Its true online double-conversion design eliminates all mains power disturbances. A rectifier converts the alternating current from the utility power to direct current. This direct current charges the batteries and powers the inverter. On the basis of this DC voltage, the inverter generates a pure sinusoidal AC voltage, which is constantly powering the loads.



Computers and peripherals are thus powered entirely by the UPS. In the event of power failure, the maintenance-free batteries power the inverter.











This manual is applicable to the following models:

- 1) H1KS, H2KS, H3KS are standard models with inbuilt battery.
- 2) H1KL, H2KL, H3KL are long backup time models, which are able to connect with the external battery bank.

1.3. Description of commonly used symbols

The following symbols will be used in this manual and may appear during the course of your practical applications. Therefore, all users should be familiar with them and understand their meanings.

Notation and explanation	
Notation	Explanation
	Alert you to pay special attention
	Caution of high voltage
	Turn on the UPS

	Turn off the UPS
	Idle or shut down the UPS
	Alternating current source(AC)
	Direct current source(DC)
	Protective ground
	Alarm silence
	Overload indication
	Battery check
	Recyclable
	Do not dispose with ordinary trash

1.4. Appearance

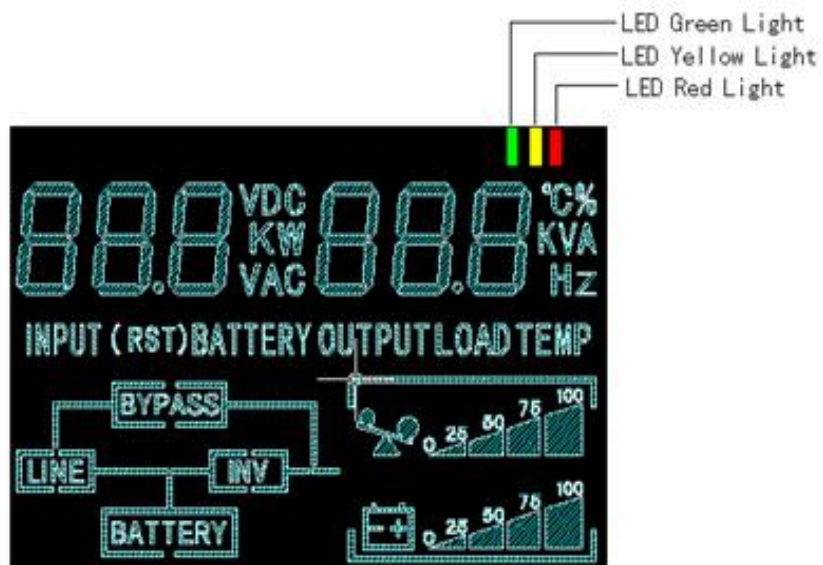

Front display panel

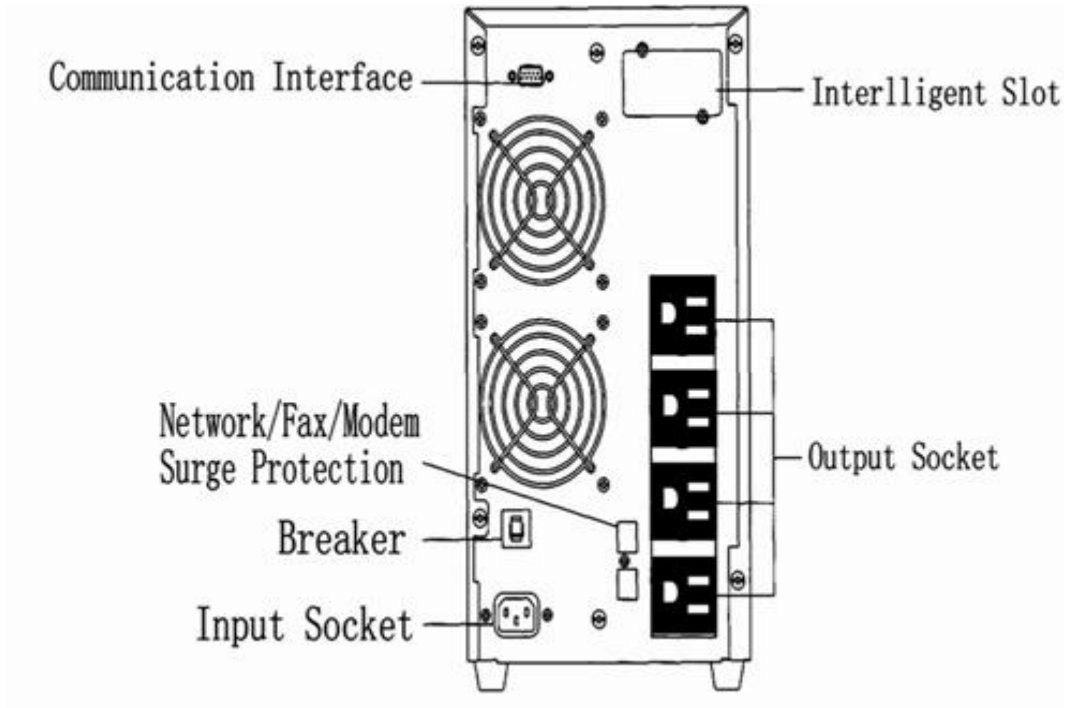

H2/3KS rear panel

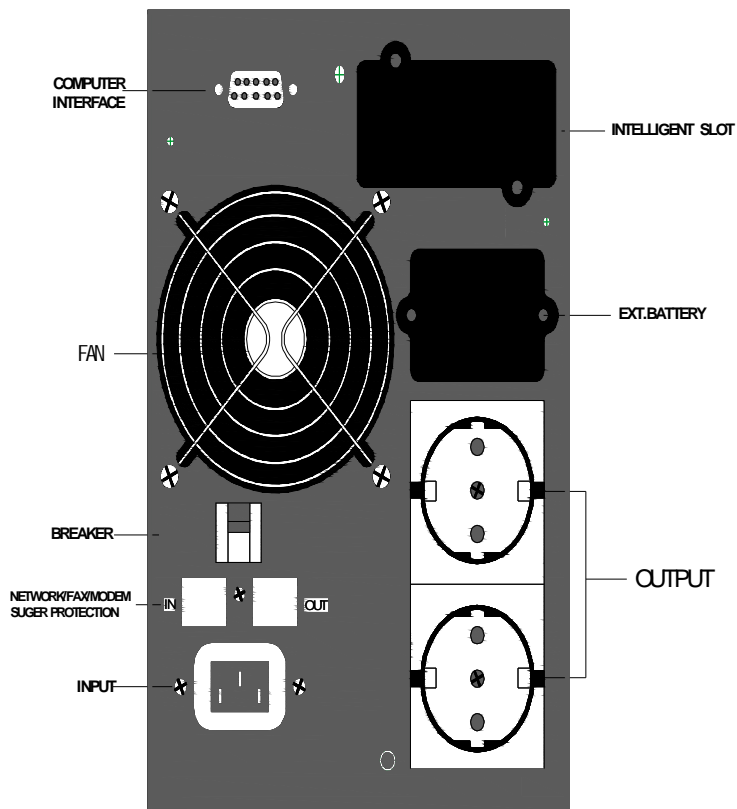

H1KL rear panel

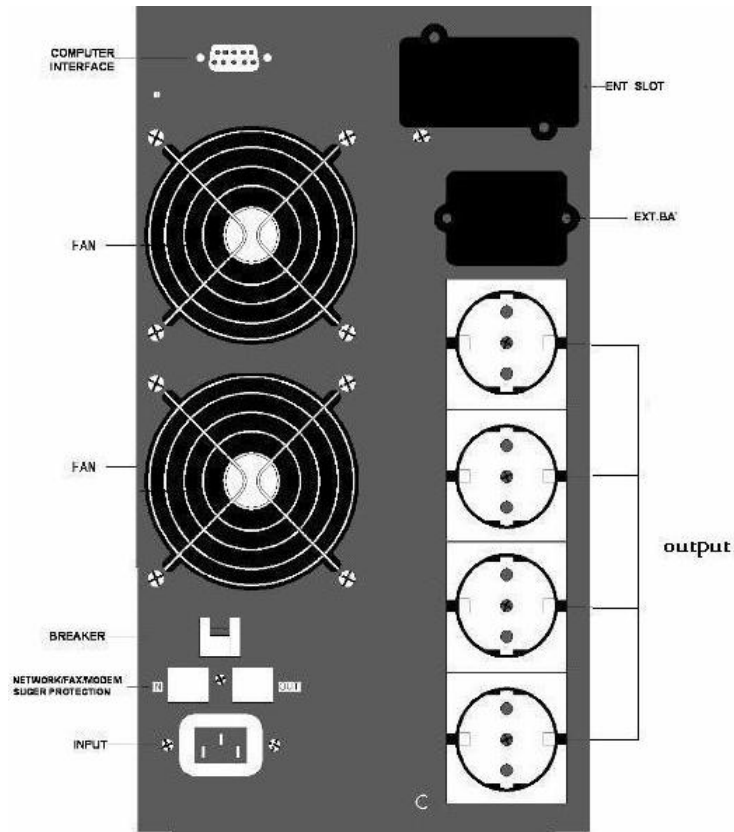

H2/3KL rear panel

1.5. Product specification and performance

1.5.1. General specification (standard models)

Model		H1KS(L)	H2KS(L)	H3KS(L)
Input	Voltage	220VAC		
	Frequency	46Hz-54Hz/56Hz-64Hz		
	Amperage(maximum)	12A	20A	30A
Output	Power rating	1KVA/0.7KW	2KVA/1.4KW	3KVA/2.1KW
	Voltage	220VAC (±2%)		
	Frequency	50/60Hz±0.2		
Batteries				
Number and type		3*12V7AH/None	8*12V7AH/None	8*12V7AH/None

1.5.2. Dimensions and weights

Model	H1KS/H1KL	H2KS/H2KL	H3KS/H3KL
Dimensions(W*H*D)(mm)	145*400*220	192*460*340	192*460*340
Net weight	14/7	34/13.5	34/14

2. Installation

2.1. Unpacking and inspection

- 1). When unpacking the UPS, please pay attention to the packing mode and the annex in which includes user-manual, warranty card, input power cable, output wiring socket. There should also have an external battery connection cable if the model of your equipment is of long backup type.
- 2). Inspect your machine to see whether it's damaged in the transportation. If damaged or some parts missing, please don't start up your UPS.
- 3). Check if the equipment is just what you wanted to purchase. You can affirm through inspecting the model number on back panel of the equipment.

2.2. Safety notes

- 1). Keep good air circulation around UPS and far away from water, flammable gas and corrosive.
- 2). Don't place UPS on the slope and there should keep good air circulation between in-vent on front panel bottom and fan out vent on back panel.
- 3). The environment temperature around UPS should keep in a range of 0°C~40°C.
- 4). There will be phenomena of condensing if the equipment is dismantled or installed under low temperature. The equipment can't be installed unless it is full dry at internal and external of the equipment, otherwise, there will be danger of electric.
- 5). The socket that supplies power to UPS should be placed near the UPS and easy.

Note:

- ★ When connecting load to UPS, first turn off load and then connect the power cable and finally turn on load one-by-one.
- ★ Plug UPS on the special power receptacle with over-current protection, the power receptacle should be connected with ground wire.
- ★ UPS is likely to have output voltage no matter whether the power input cable is plugged in utility socket. If you wish UPS don't have output, firstly break off the switch and then cancel utility power supply.
- ★ For standard unit, it is recommended the batteries are charged for eight hours prior to use. UPS can automatically charge batteries as long as UPS put through power. UPS can also be used at once if battery hasn't been charged, but the back-up time will be less than the standard value.
- ★ When connect inductance load such as laser printer to UPS, the capacity of UPS is reckoned according to the loads startup power because the startup power is higher.

2.3. The description of front panel and display lamp

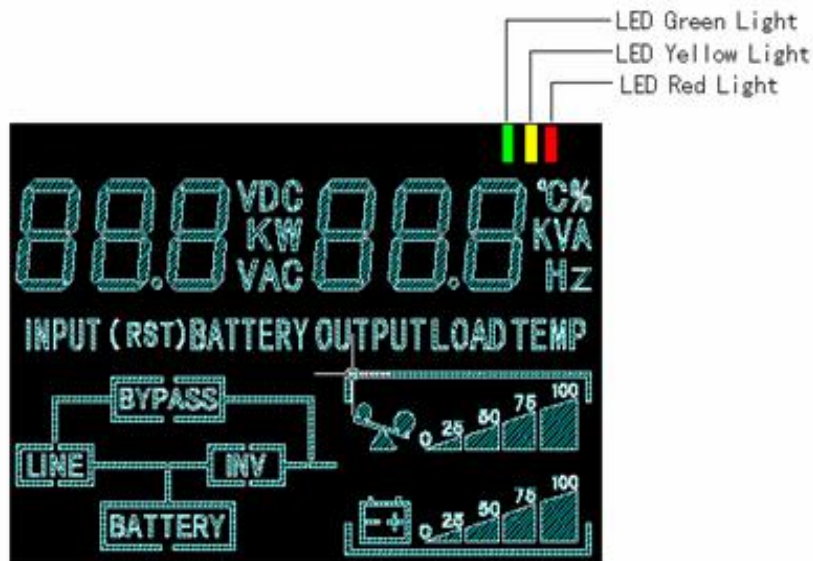

Description of the front panel

LCD panel section

- The first line is the numeric section, and is consisted of two small numeric sections and the related unit section on the right side. It is used to display the numerical value of the certain item on the second line.
- The second line is the section of the items which include input, battery, output, load and temperature, etc.
- The third line is the figure section which is consisted with two parts , the parts on the left shows the working status of UPS, the parts on the right shows the load capacity (on the top) and battery capacity (on the bottom) by schematic figure.

LED panel section

- Power ON/OFF: to turn on the UPS simply by pressing the “ON” button on the front panel continuously for 1 second. Press the “OFF” button on the front panel continuously for 1 second to turn off the UPS.
- Bypass LED (orange LED): whenever the bypass LED is turned on, it shows that the loading current is supplied directly from the utility power.
- Utility power LED (green LED): whenever the utility power LED is turned on, it shows that the utility power is normal.
- Inv LED (green LED): whenever the INV LED is turned on, it shows that the loading current is supplied from utility power or battery via the inverter.
- Battery LED (orange LED): whenever the battery LED is turned on, it shows that the loading current is supplied from battery via the inverter.
- Fault LED (red LED): whenever the fault LED is turned on, it shows that the UPS is in abnormal condition.
- #2-#6 LEDs (the #2 LED is orange and the #3-#6 LEDs are green): these LEDs indicate the percentage of the load capacity in utility power mode or battery capacity level in battery mode.



Description of the buttons

Buttons' function:

I ON/OFF button

Press and hold for some time to turn on/off the UPS.

I FUNCTION button

Press and hold for some time on utility mode: UPS runs a self-test function.

Press and hold for some time on battery mode: mute function.

I INQUIRING button

Press for short time: indicate the items of the second row item section orderly. Press and hold for some time: circularly and orderly display the items from INPUT, BATTERY, OUTPUT, LOAD & TEMPERATURE every 2 seconds.

When you press and hold the button for some time again, it will turn to static output status.

2.4. UPS input connection

When connect power cable, please use suitable socket with over-current protection. The rating for H1KS(L) should be above 6A, for H2KS(L) should be above 12A, for H3KS(L) should be above 16A.

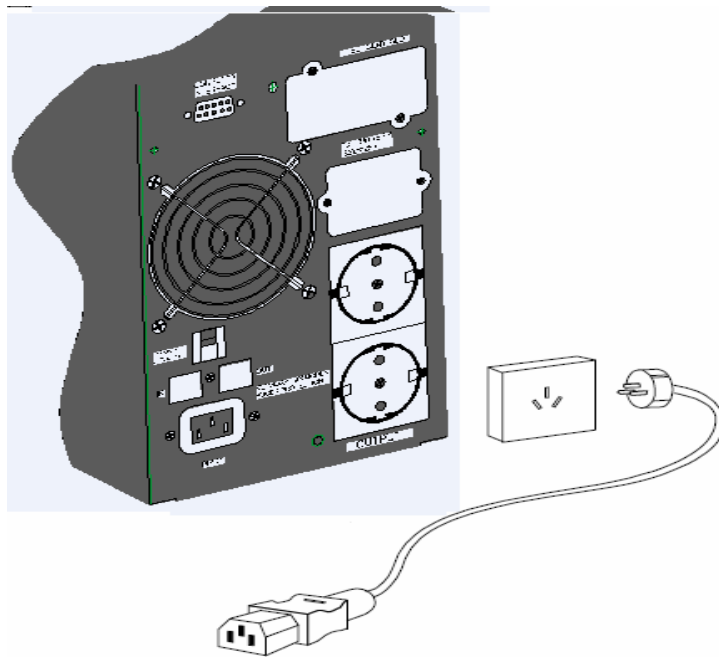

UPS input connection

2.5. UPS output connection

- 1). Output of H1KS(L) use socket only, please directly plug the load cable into the output socket.
- 2). Output of H2KS(L) and H3KS(L) not only provide socket but also offer high-current output wiring socket, which make output wiring become easy.

UPS model	Output socket	Wiring socket
H1KS(L)	3	None
H2/3KS(L)	4	Yes

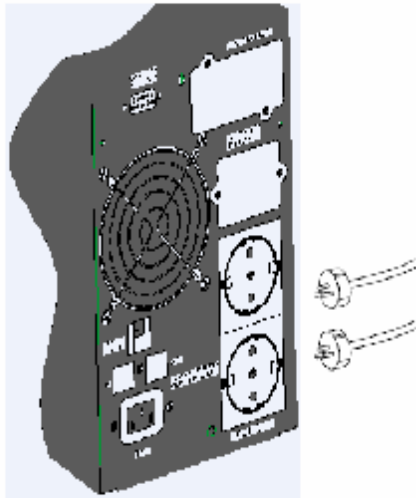

UPS output connection

2.6. External battery connection

1). Choose correct battery voltage according to the model

The batteries can't be more or less connected, otherwise UPS will work abnormal or be damaged. Battery voltage for H1KL is 36VDC; for H2KL is 96VDC; for H3KL is 96VDC.

2). One end of external battery cable is connected to UPS; the other end is open style two cables used to connect to battery pack. The process of connecting battery is very important. Operator must obey the instructions.

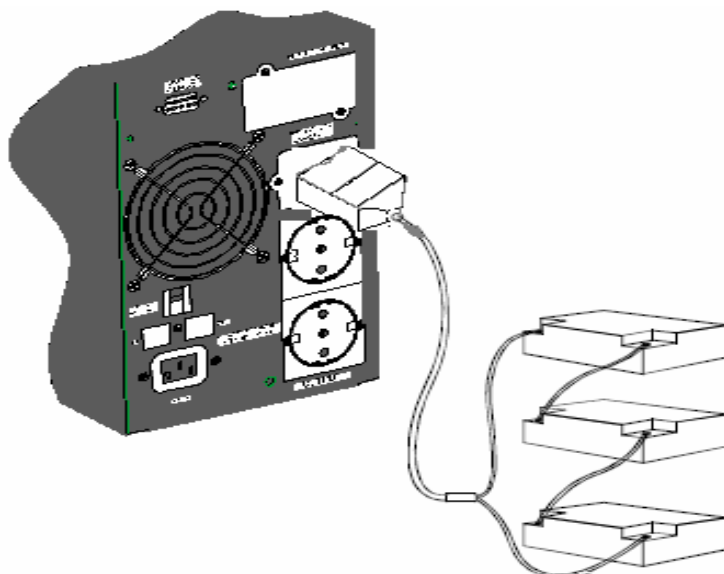

Long backup external battery connection

- A. First connect battery group in series and ensure correct battery voltage.
- B. Extended battery cable must be connected to battery first (do not connect to UPS first; otherwise there will be danger of (electric shock). Red cable connect with battery anode “+” and black cable connect with cathode” –“.
- C. Don't connect any load to UPS, put through utility to UPS after the input wire has been connected well.
- D. After plug the battery extended cable into UPS battery socket, the connection is completed, at the same time UPS starts to charge batteries.

3. Operation and operating mode

3.1. Operation

3.1.1. Operation on utility mode

- 1). Once utility is plugged in, the internal charger starts to charge batteries, at this point the yellow LED is on and LCD status figure shows block “LINE” and “BATTERY” and the output voltage is zero, which means UPS has no output.
- 2). Press and hold the ON/OFF button for more than 2 seconds to turn on the UPS, then it will turn on the internal inverter.
- 3). Once turned on, the UPS will perform a self-test function, when the green LED lights on, LCD status figure shows block “LINE” and “INV” and “BATTERY”, that means UPS is working in utility mode.

3.1.2. Start up UPS by DC when utility is disconnected

- 1). When utility is disconnected, press and hold the ON/OFF button for more than 2 seconds to cold start the UPS.
- 2). The cold start is the same operation as when UPS is started with the utility in, and LCD status figure shows block “BATTERY” and “INV”, which means UPS is working in battery mode.

3.1.3. Turn off UPS in utility mode

- 1). Press and hold the ON/OFF button for more than 2 seconds to turn off the UPS, then it will turn off the internal inverter.
- 2) When turning off the UPS, UPS will run a self-test function, green LED will be off and yellow LED will be on, LCD status figure shows block “LINE” and “BATTERY”, which means UPS has no output but still charge the battery.

3.1.4. Turn off UPS in battery mode

- 1). Press and hold the ON/OFF button for more than 2 seconds to turn off the UPS.
- 2). When turning off the UPS, UPS will run a self-test function, UPS has no output once there is no display

on front panel.

3.1.5. UPS self-test/mute test operation

1). When UPS is on utility mode, press and hold the FUNCTION button for 1 second, the buzzer will sound once every 4 seconds, the LED lights light around at the same time as the UPS runs self-testing, and it will last for 10 seconds.

2). When UPS is on battery mode, the buzzer stops beeping if you press and hold the FUNCTION button for 1 second, and it will restart to beep if you press and hold the ON/OFF button for one more second.

* Off-charging model

When utility is on and the UPS is not switched on, then the LCD status figure will show block "LINE" and "BATTERY", without output. The UPS will charge the battery in this mode.

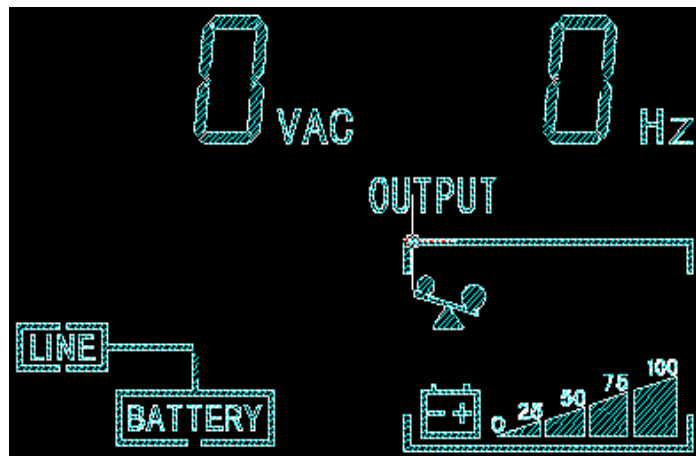

Off-charging mode

3.2. Operating mode

3.2.1. Utility mode

On utility mode, the indication and displays are as following figures:

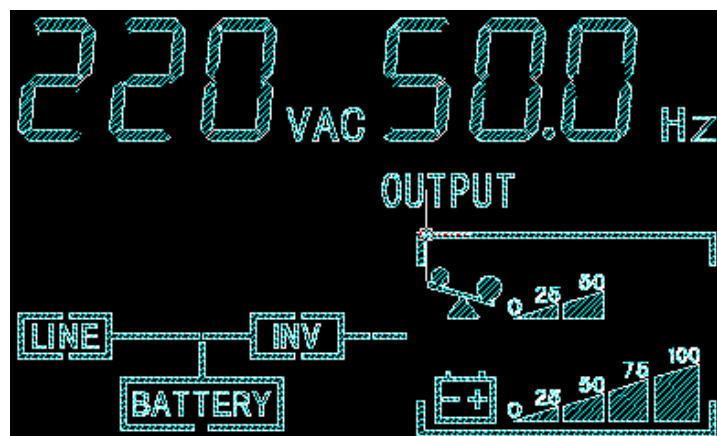

Utility mode

Green LED is on, LCD status figure shows block "LINE" and "BATTERY" and "INV".

1). If the INPUT letters in the item section (the second row on LCD display) flashes, it indicates the line and neutral are incorrect.

2). If load capacity graph in the graphic section (the third row on LCD display) flashes, yellow LED is on and the buzzer beeps once half second, it reminds that UPS carries over 100% load and you should remove the unnecessary load until the displayed load is below 100%.

3). If battery capacity graph in the graphic section (the third row on LCD display) flashes, yellow LED is on, it reminds that UPS is disconnected with batteries or battery voltage is low, and you should firstly check whether the battery connection is ok, if yes, the batteries may be fault and need to be replaced. You can press the FUNCTION button for 1 second to do the manual self-test, for more details please refer to the troubleshooting table.

3.2.2. Battery mode

On battery mode, the indication and displays are as following figure:

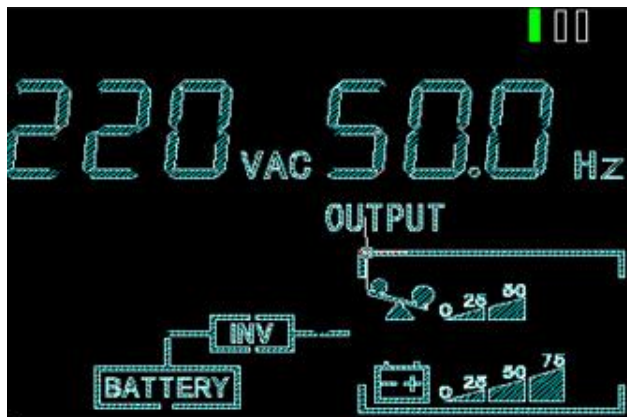

Battery mode

Green LED is on, LCD status figure shows block "BATTERY" and "INV"

1). On battery mode, the buzzer will beep once every 4 seconds to provide an audible alarm, press and hold the function button for more than 1 second, the buzzer will stop beeping, press and hold the FUNCTION button for one more second, the buzzer will beep again.

2). If battery capacity graph in the graphic section (the third row on LCD display) flashes, yellow LED is on, the buzzer beeps once every second, it means the battery voltage is discharged to minimum protection voltage, and reminds users that the battery capacity is diminished and should save all data and works and then switch off the equipments.

3). You can test UPS back up function by disconnecting the utility.

4). If the INPUT letters in the item section (the second row on LCD display) flashes, it means the input voltage or frequency is beyond the extension.

3.2.3. Fault mode

The front panel indication and display is as following:



Fault mode

Red LED is on. The digital section indicates the fault code. For more details please refer to the abnormal process table.

Notice:

★ The following process must be performed if UPS is connected with generator:

First turn on generator , after it runs stably (at this time ensure UPS is no-load connected) connect output power of generator to UPS input terminal , then turn on UPS. After UPS turned on, please connect load one-by-one.

★ It is recommended that the generator capacity is as twice as UPS rated capacity.

3.2.4. Backup time for the standard model

The backup time of the long backup time model is dependent on the external battery pack capacity and the load level as well as other factors.

The backup time of standard model may vary from different models and load level, please refer to the following:

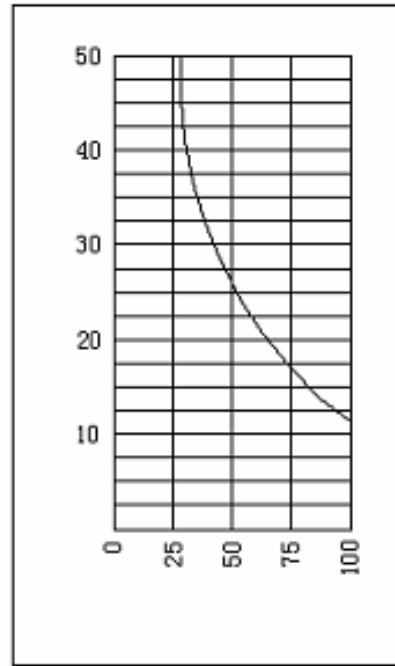
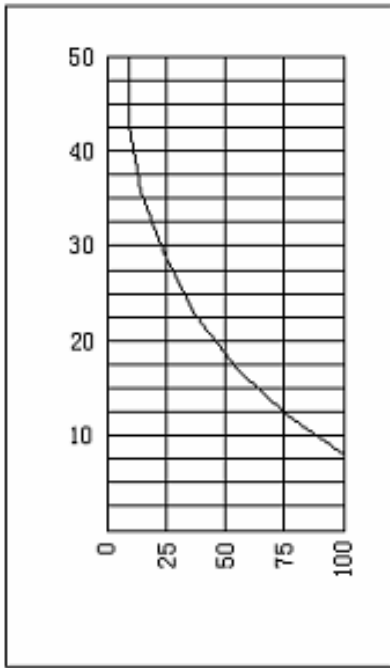

3.2.5. Communication port

Intelligent slot

This series is equipped with an intelligent slot for web power (optional accessory) or other optional card to achieve remote management of the UPS through internet/intranet. Please contact your local distributor for further information,

RS232 Interface

The following are the descriptions and pin assignment of RS232 DB-9 port:

- Baud rate: 2400bps
- Data bit: 8 bit
- Ending bit: 1 bit
- Parity bit: none

DB-9 pin assignment:

Pin number	Function description	I/O
3	Rx	Input
2	Tx	Output
5	Ground	GND

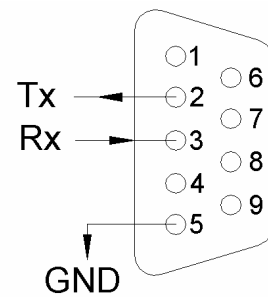

RS232 interface

Optional AS400 interface

This optional AS400 card provides dry contact closure signal "OPEN" or "CLOSE".

The following are the pin assignment and the descriptions of AS400 card:

PIN1: UPS failure (normally open, active close)

PIN2: Summary

PIN3: Ground

PIN4: Remote shutdown

PIN5: Common

PIN6: Bypass active (relay close)

PIN7: Battery low

PIN8: UPS On (relay close)

PIN9: Utility Power failure (normally open, active close)

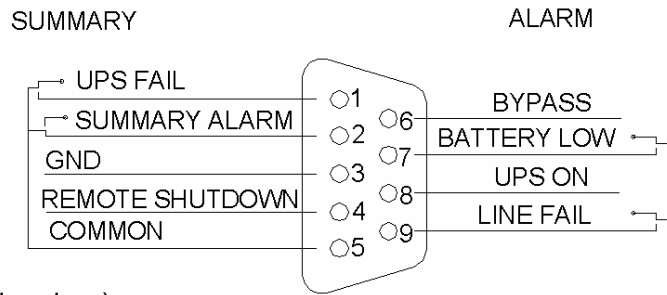

AS400 Interface

3.2.6. Battery maintenance

This series UPS only requires minimal maintenance. The battery used for standard models are value regulated sealed lead-acid maintenance free battery. These models require minimal repairs. The only requirement is to charge the UPS regularly in order to maximize the expected life of the battery. When being connected to the utility power, whether the UPS is turned on or not, the UPS keeps charging the batteries and also offers the protective function of overcharging and over-discharging.

- I The UPS should be charged once every 4 to 6 months if it has not been used for a long time.
- I In the regions of hot climates, the battery should be charged and discharged every 2 months. The standard charging time should be at least 12 hours.
- I Under normal conditions, the battery life lasts 3 to 5 years. In case if the battery is found not in good condition, earlier replacement should be made. Battery replacement should be performed by qualified personnel.
- I Replace batteries with the same number and same type of batteries.
- I Do not replace the battery individually. All the batteries should be replaced at the same time following the instructions of the battery supplier.

Normally, the batteries should be charged and discharged once every 4 to 6 months. Charging should begin after the UPS shuts down automatically in the course of discharging, the standard charging time for the standard UPS should be at least 12 hours.

Notice:

★ Before replacing batteries, first please break off the utility switch and remove all your metallic adornment such as finger ring, watch and so on.

★ Please use the screwdriver with insulating handle. Do not lay the tools or metallic goods on the battery

★ It is normal to have sparks when you connect battery wire to battery, it does not do harm to your body safety .

★ No anti-connection or short circuit between the battery anode and cathode forever

4. Notes for battery disposal and battery replacement

- The battery of standard unit is of valve regulated, maintenance free. It can attain expectant life only by keeping frequent charging. Regardless of UPS on or off when UPS connects to utility power, the battery is charged all the time and UPS offers protection for over-charge and over-discharge.
- Normally the battery life is three to five years and the battery must be replaced ahead of time once there presents any abnormal status. The battery replacement must only be performed by qualified personnel.
- It is inadvisable to replace a single battery. Operator should obey the instruction of battery distributor when replacing all batteries.
- The batteries should be charged and discharged once every four to six months. After UPS discharged to off, the batteries should be recharged. The charge time of standard unit must be more than 12 hours.
- The battery must be charged and discharged once every two months in high-temperature area. The charge time of standard units must be more than twelve hours.

1. If it is necessary to replace any connection cables, please purchase the original materials from the authorized distributors or service centers, so as to avoid overheat or spark resulting in fire due to insufficient capacity.

2. Do not dispose of batteries or battery packs in a fire, they may explode.

3. Do not open or mutilate batteries, released electrolyte is highly poisonous and harmful to the skin and eyes.

4. Do not short the positive and negative of the battery electrode, otherwise, it may result in electric shock or fire.

5. Make sure that there is no voltage before touching the batteries. The battery circuit is not isolated from the input potential circuit. There may be hazardous voltage between the battery terminals and ground.

6. Even though the input breaker is disconnected, the components inside the UPS are still connected with the batteries, and there are potential hazardous voltages. Therefore, before any maintenance and repairs work is carried out, switch off the breaker of the battery pack or disconnect the jumper wire of connecting between the batteries.

7. Batteries contain hazardous voltage and current. Battery maintenance such as the battery replacement must be carried out by qualified personnel who are knowledgeable about batteries. No other persons should handle the batteries.

5. Troubles shooting

The following messages are the messages that users would find on UPS when it meets some problem, with the use of such messages, users can know where the problems are and how to deal with such problems.

- ◆ Fault indicator on, indicates UPS has detected some fault. Buzzer beeps, indicate UPS need to be paid attention to.
- ◆ Several fault indicators and status indicators on, are to help the user to diagnose fault.

Fault	Causation	Solution
the “ INPUT” letters in the item section (the second row on LCD display) flashes	Utility voltage or frequency exceeds UPS input range (beep 2 times every 1s when startup, beep for 8 times)	UPS is working on battery mode, save disk and close the programs, make sure utility voltage and frequency is in the range of normal
	Anti-connection of utility line and neutral, UPS beeps once per 2m	Re-connect, make a correct connection
Battery indicator flashes	Battery low voltage or battery not connected	Check UPS battery, re-connect battery well, if battery damaged, replace it.
Utility normal, but UPS has no input	UPS input breaker open circuit	Manually reposit breaker
Short back up time	Battery not charged enough	Keep UPS connecting with utility for more 8 hours, recharge battery
	UPS overloaded	Check load capacity, remove some redundant loads
	Battery aged	Remove battery, please contact franchiser to get battery and relative subassembly.
UPS don't startup after pressing the ON button	Short holding time	Press and hold the ON button for more than 1s to startup UPS
	UPS has no battery connected or battery voltage low and too many loads connected	Connect UPS battery well, if battery voltage low, please turn off UPS and take off some loads, then startup UPS
	Fault occur inside UPS	Contact supplier for servicing

When you contact the service center, please provide the following information:

- Model No. and the serial No. of the UPS;
- The date when the problem arose;
- Complete description of the problem, including the LED display, alarm warning, and power condition and load capacity. If your UPS is a long backup time model, you may also provide the battery

information.

Appendix: EMC grade standards

H series UPS are manufactured according to the following:

EMC international grade standard:

International standard code	Grade
*EMC	
IEC61000-4-2(ESD)	Level 4
IEC61000-4-3(RS)	Level 3
IEC61000-4-4(EFT)	Level 4
IEC61000-4-5(Surge)	Level 4
*EMI	
IEC62040-2	Class B